

Operating Temperature: 0°C~70°C
 Operating Humidity: 20%~80% (no condensation)
 Storage Temperature: -25°C~85°C
 Storage Humidity: 20%~80% (no condensation)

L:
 CBL-43PU3.1G1SL-3m 3000mm±20mm

USB A(M) PIN OUT USB C(M)

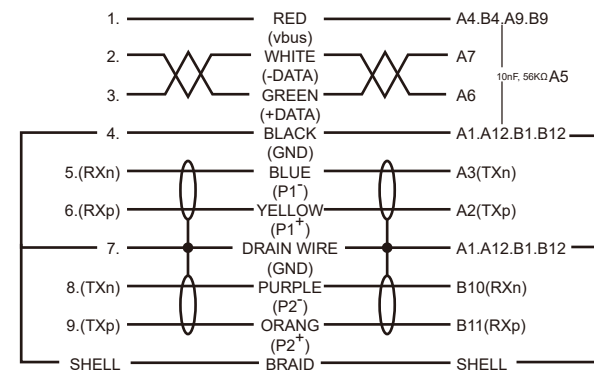

No	MATERIALS LIST:
1.	CABLE:UL20276 (1P*30SC#+D+AL+Mylar)*2C+1P*32#+1C*24 OD:4.3mm PVC JACKET COLOR:BLUE
2.	CONNECTOR:USB 3.0 A/M, 9P, BLUE INSULATOR SOLDER TYPE, NICKEL PLATED SHELL
3.	CONNECTOR:USB 3.1 TYPE-C, MALE, NICKEL PLATED SHELL
4.	ABS ASSEMBLY HOUSING,BLUE COLOR
5.	SCREW:#3x15.8 M2
6.	SCREW:#3x20.7 M2

Jargy part no.	Client part no.	Approved	SCALE	UNIT
CBL-43PU3.1G1SL-Xm				mm
Drawing Name		Drawn	Date	REV.
USB 3.1 GEN 1 A to C M/M				1.0

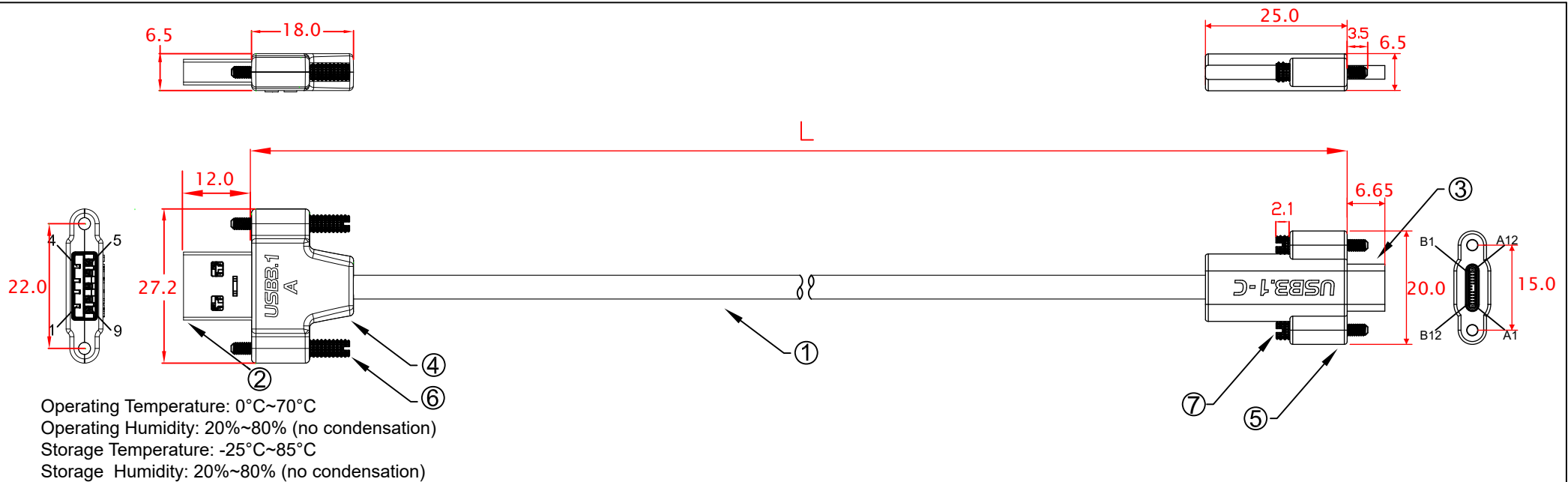

L:
 CBL-43PU3.1G1SL-3m 3000mm±20mm

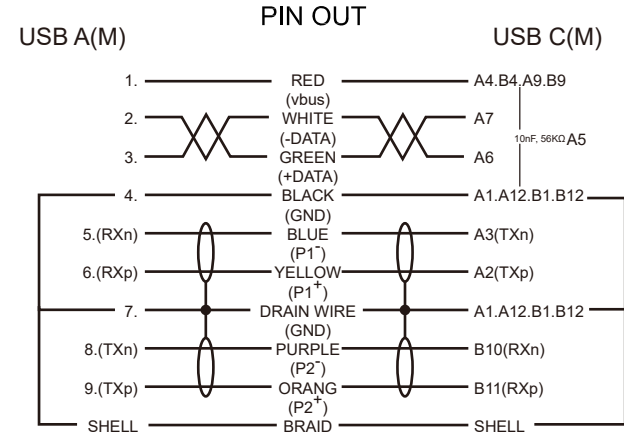

No	MATERIALS LIST:
1.	CABLE:UL20276 (1P*30SC#+D+AL+Mylar)*2C+1P*32#+1C*24 OD:4.3mm PVC JACKET COLOR:BLUE
2.	CONNECTOR:USB 3.0 A/M, 9P, BLUE INSULATOR SOLDER TYPE, NICKEL PLATED SHELL
3.	CONNECTOR:USB 3.1 TYPE-C, MALE, NICKEL PLATED SHELL
4.	ABS ASSEMBLY HOUSING,BLUE COLOR
5.	PVC MOLDED HOUSING, BLUE COLOR
6.	SCREW:#3x20.7 M2
7.	SCREW:#3x15.8 M2

Jargy part no.	Client part no.	Approved	SCALE	UNIT
CBL-43PU3.1G1SL-Xm				mm
Drawing Name		Drawn	Date	REV.
USB 3.1 GEN 1 A to C M/M				1.0

Mobile Computing **JARGY**

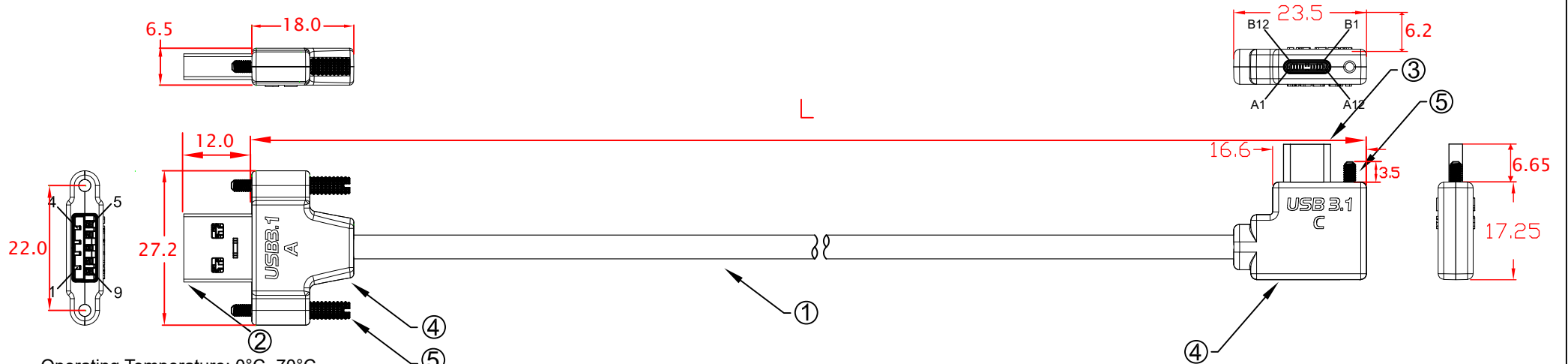

Operating Temperature: 0°C~70°C
 Operating Humidity: 20%~80% (no condensation)
 Storage Temperature: -25°C~85°C
 Storage Humidity: 20%~80% (no condensation)

L:
 CBL-43PU3.1G1SS-3mLRA 3000mm±20mm

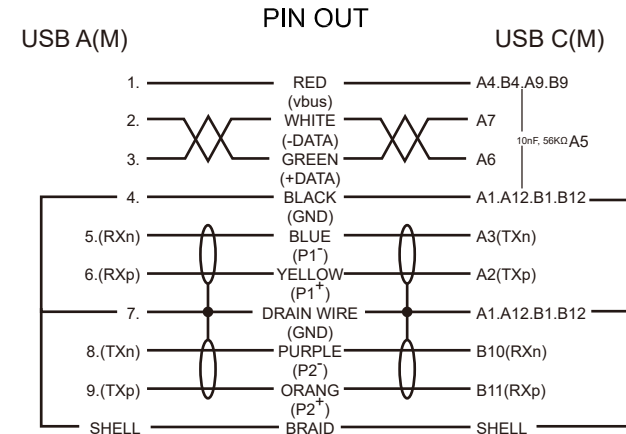

No	MATERIALS LIST:
1.	CABLE:UL20276 (1P*30SC#+D+AL+Mylar)*2C+1P*32#+1C*24 OD:4.3mm PVC JACKET COLOR:BLUE
2.	CONNECTOR:USB 3.0 A/M, 9P, BLUE INSULATOR SOLDER TYPE, NICKEL PLATED SHELL
3.	CONNECTOR:USB 3.1 TYPE-C, MALE, NICKEL PLATED SHELL
4.	ABS ASSEMBLY HOUSING,BLUE COLOR
5.	SCREW:#3x20.7 M2

Jargy part no.	Client part no.	Approved	SCALE	UNIT
CBL-43PU3.1G1SS-XmLRA				mm
Drawing Name		Drawn	Date	REV.
USB 3.1 GEN 1 A to C M/M				1.0

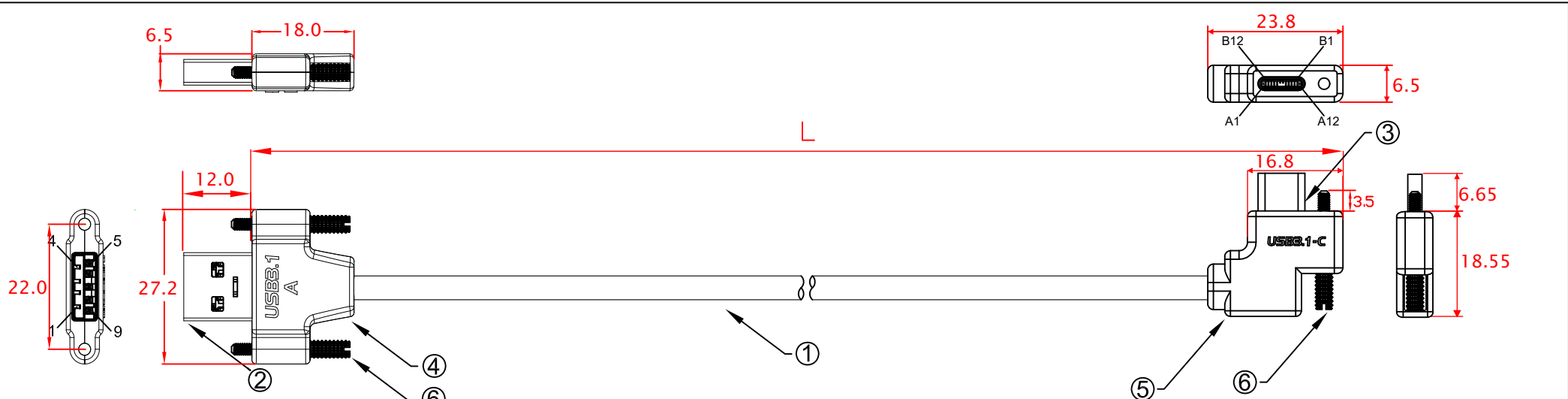

Operating Temperature: 0°C~70°C
 Operating Humidity: 20%~80% (no condensation)
 Storage Temperature: -25°C~85°C
 Storage Humidity: 20%~80% (no condensation)

L:
 CBL-43PU3.1G1SS-3mLRA 3000mm±20mm

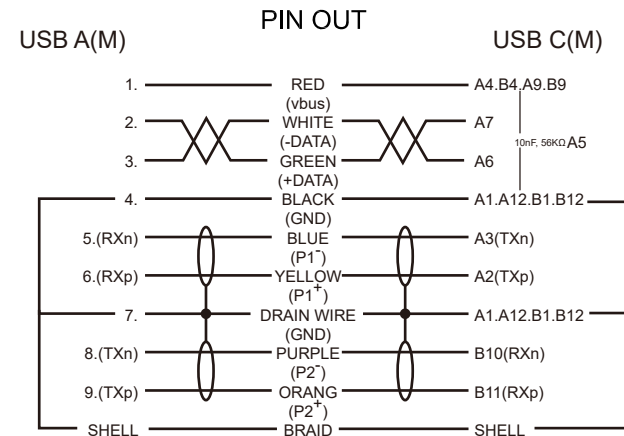

No	MATERIALS LIST:
1.	CABLE:UL20276 (1P*30SC#+D+AL+Mylar)*2C+1P*32#+1C*24 OD:4.3mm PVC JACKET COLOR:BLUE
2.	CONNECTOR:USB 3.0 A/M, 9P, BLUE INSULATOR SOLDER TYPE, NICKEL PLATED SHELL
3.	CONNECTOR:USB 3.1 TYPE-C, MALE, NICKEL PLATED SHELL
4.	ABS ASSEMBLY HOUSING,BLUE COLOR
5.	PVC MOLDED HOUSING, BLUE COLOR
6.	SCREW:#3x20.7 M2

Jargy part no.	Client part no.	Approved	SCALE	UNIT
CBL-43PU3.1G1SS-XmLRA				mm
Drawing Name		Drawn	Date	REV.
USB 3.1 GEN 1 A to C M/M				1.0

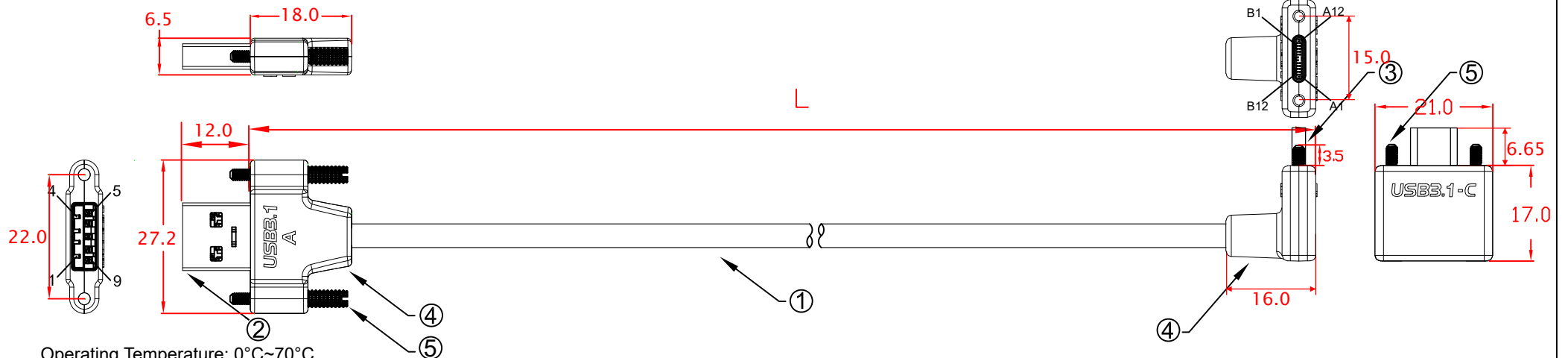

Operating Temperature: 0°C~70°C
 Operating Humidity: 20%~80% (no condensation)
 Storage Temperature: -25°C~85°C
 Storage Humidity: 20%~80% (no condensation)

L:
 CBL-43PU3.1G1SS-3mUDA 3000mm±20mm

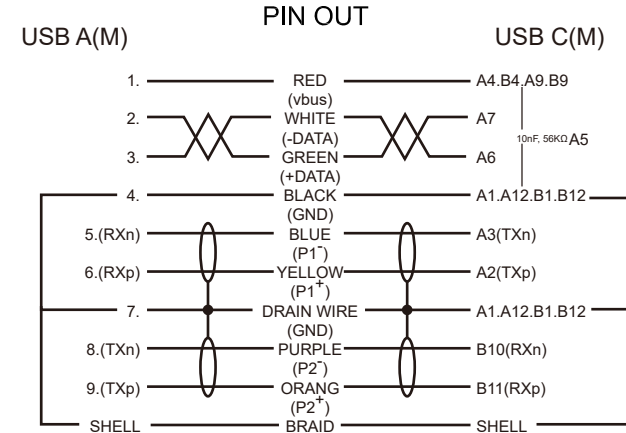

No	MATERIALS LIST:
1.	CABLE:UL20276 (1P*30SC#+D+AL+Mylar)*2C+1P*32#+1C*24 OD:4.3mm PVC JACKET COLOR:BLUE
2.	CONNECTOR:USB 3.0 A/M, 9P, BLUE INSULATOR SOLDER TYPE, NICKEL PLATED SHELL
3.	CONNECTOR:USB 3.1 TYPE-C, MALE, NICKEL PLATED SHELL
4.	ABS ASSEMBLY HOUSING,BLUE COLOR
5.	SCREW:#3x20.7 M2

Jargy part no.	Client part no.	Approved	SCALE	UNIT
CBL-43PU3.1G1SS-XmUDA				mm
Drawing Name		Drawn	Date	REV.
USB 3.1 GEN 1 A to C M/M				1.0